XIX. Chemistry, Grades 9/10

Grades 9/10 Chemistry Test

The spring 2006 Grades 9/10 MCAS Chemistry Test was based on learning standards in the Chemistry content strand of the Massachusetts *Science and Technology/Engineering Curriculum Framework* (2001). These learning standards appear on pages 63–67 of the *Framework*.

The *Science and Technology/Engineering Curriculum Framework* is available on the Department Web site at www.doe.mass.edu/frameworks/scitech/2001/0501.pdf.

The reporting of results of the Grades 9/10 Chemistry Test is limited to *Test Item Analysis Reports*. No scaled score or performance level results are available.

Test Sessions

The MCAS Grades 9/10 Chemistry Test included two separate test sessions. Each session included multiple-choice and open-response questions.

Reference Materials and Tools

Each student taking the Grades 9/10 Chemistry Test was provided with a *Chemistry Formula and Constants Sheet/Periodic Table of the Elements*. Copies of both sides of this reference sheet follow the final question in this chapter.

Each student also had sole access to a calculator with at least four functions and a square root key.

The use of bilingual word-to-word dictionaries was allowed for limited English proficient students only, during both Chemistry test sessions. No other reference tools or materials were allowed.

Cross-Reference Information

The table at the conclusion of this chapter indicates the *Framework* learning standard that each item assesses. The correct answers for multiple-choice questions are also displayed in the table.

Chemistry

SESSION 1

DIRECTIONS

This session contains twenty-three multiple-choice questions and three open-response questions. Mark your answers to these questions in the spaces provided in your Student Answer Booklet. You may work out solutions to multiple-choice questions in the test booklet.

- 1 The figure below shows part of the periodic table.

Cu
Ag
Au

Which of the following is an accurate comparison of the atomic number and mass of copper (Cu) and gold (Au)?

- A. Au has a smaller atomic mass and fewer electrons than Cu.
- B. Au has the same atomic mass as Cu but a greater atomic number.
- C. Au has the same atomic number as Cu but a much greater atomic mass.
- D. Au has both a greater atomic number and a greater atomic mass than Cu.

- 2 Which of the following is an example of a chemical change?

- A. burning a scented candle
- B. cutting an apple into slices
- C. freezing liquid water into an ice cube
- D. melting a stick of butter to pour over popcorn

- 3 A chemist wishes to react 500 g of marble (CaCO_3) with an excess of hydrochloric acid. In which of the following forms will the marble react **most** rapidly?

- A. small chips
- B. fine powder
- C. a solid cube
- D. a solid sphere

- 4 Which of the following chemical reactions is a decomposition reaction?

- A. $\text{BaCO}_3 \rightarrow \text{BaO} + \text{CO}_2$
- B. $2\text{Ca} + \text{O}_2 \rightarrow 2\text{CaO}$
- C. $3\text{Br}_2 + 2\text{FeI}_3 \rightarrow 2\text{FeBr}_3 + 3\text{I}_2$
- D. $\text{MgCl}_2 + \text{H}_2\text{SO}_4 \rightarrow \text{MgSO}_4 + 2\text{HCl}$

- 5 Which of the following describes a particle that contains 36 electrons, 49 neutrons, and 38 protons?
- A. an ion with a charge of 2-
 - B. an ion with a charge of 2+
 - C. an atom with a mass of 38 amu
 - D. an atom with a mass of 49 amu
- 6 Soda ash, or sodium carbonate, is used in glassmaking. It is composed of sodium ions and carbonate ions. Which of the following is the chemical formula of sodium carbonate?
- A. NaCO_3
 - B. Na_2CO_3
 - C. $\text{Na}_4\text{C}_2\text{O}_6$
 - D. $\text{Na}(\text{CO}_3)_2$
- 7 Sodium hydroxide (NaOH) is a strong base. The dissociation of NaOH in an aqueous solution is given below.

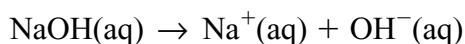

According to the Arrhenius theory, why is sodium hydroxide a base?

- A. NaOH is a neutralizer.
- B. NaOH is a proton acceptor.
- C. NaOH is a hydroxide ion donor.
- D. NaOH is an electron pair provider.

- 8 The illustration below shows a hot-air balloon. The pilot can change the altitude of the hot-air balloon by changing the temperature of the gas inside the balloon. When the gas is heated, the balloon rises.

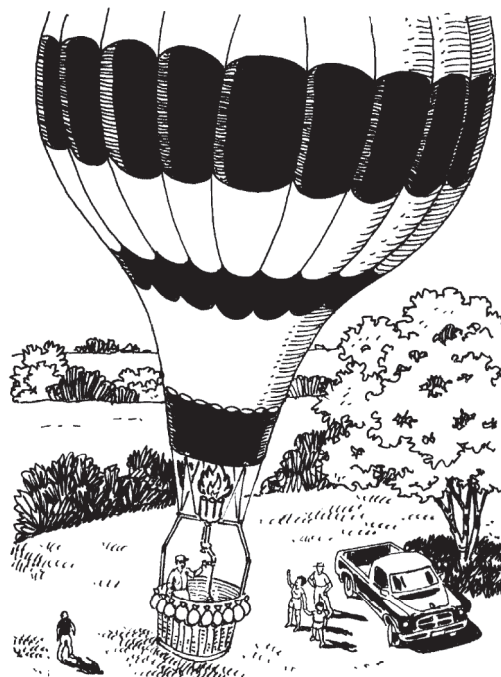

Which of the following **best** explains this phenomenon?

- A. Heating the gas reduces its pressure.
- B. Heating the gas decreases its density.
- C. Heating the gas decreases its molecular motion.
- D. Heating the gas reduces the frequency of the gas molecules' collisions.

9 Deuterium (${}^2_1\text{H}$) and protium (${}^1_1\text{H}$) are two isotopes of hydrogen. Which of the following statements **best** compares a deuterium atom to a protium atom?

- A. The deuterium atom has a smaller net charge.
- B. The deuterium atom has more electron orbitals.
- C. The deuterium atom has a smaller atomic radius.
- D. The deuterium atom has more particles in its nucleus.

10 Fluorine gas is produced according to the following reaction.



Under which of the following conditions will maximum production of fluorine gas occur?

- A. The temperature is reduced until the BrF_5 condenses.
- B. The reaction takes place in the presence of bromine gas.
- C. Additional fluorine gas is continuously pumped into the container.
- D. Fluorine gas is removed from the system as it is formed.

Question 11 is an open-response question.

- **BE SURE TO ANSWER AND LABEL ALL PARTS OF THE QUESTION.**
- **Show all your work (diagrams, tables, or computations) in your Student Answer Booklet.**
- **If you do the work in your head, explain in writing how you did the work.**

Write your answer to question 11 in the space provided in your Student Answer Booklet.

- 11 The diagram below represents an incandescent light bulb.

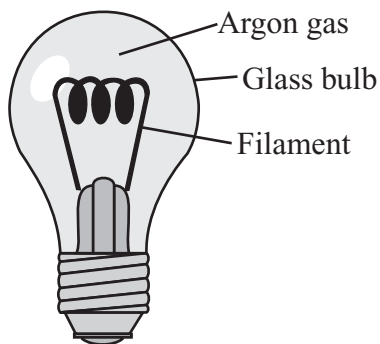

Incandescent light bulbs produce light by heating a filament. Filling the bulb with an inert gas like argon makes the filament last longer. The bulb shown has a volume of 150 cm^3 and contains a mass of 0.16 g of argon (atomic mass of argon is 39.9 amu).

- If neon were used in place of argon, what mass of neon would be contained in the bulb (atomic mass of neon is 20.2 amu)? Assume that the bulb is filled to the same pressure. Explain your answer.
- What happens to the gas particles inside the bulb when it is turned on? Explain your answer in terms of the kinetic molecular theory.

Mark your answers to multiple-choice questions 12 through 24 in the spaces provided in your Student Answer Booklet. Do not write your answers in this test booklet, but you may work out solutions to multiple-choice questions in the test booklet.

- 12 The diagram below represents a sodium ion surrounded by several water molecules.

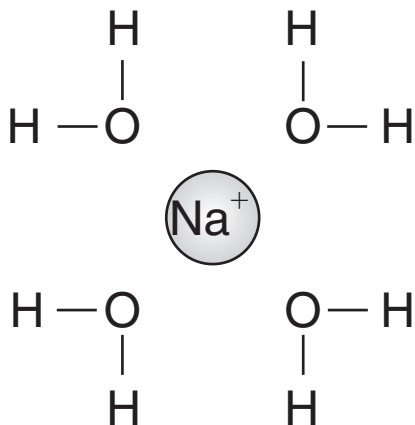

This diagram can be used to represent which of the following?

- A. how sodium ions dissolve in water
- B. how sodium is neutralized by water
- C. how sodium metal makes bubbles in water
- D. how sodium ions precipitate out as a solid in aqueous solution

- 13 The label below contains information about an unknown metal.

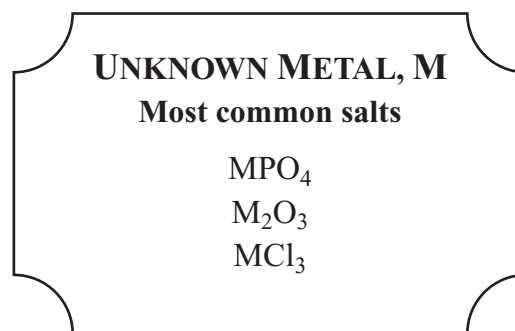

How many valence electrons does the unknown metal have?

- A. 1
- B. 3
- C. 4
- D. 6

- 14 The final elements produced by radioactive decay differ from the original radioactive elements because the nuclei of the final elements are always

A. more stable.
B. increased in mass.
C. half as radioactive.
D. positively charged.

- 15 An unbalanced chemical equation is shown below.



What are the coefficients of the balanced equation?

A. 2:1:3
B. 2:2:3
C. 3:1:2
D. 3:2:2

- 16 Block X and Block Y have the same mass. Both blocks are placed into a container of pure water. Block X floats in the water, and Block Y sinks to the bottom of the container.

Which of the following statements is an accurate conclusion from this demonstration?

A. Block Y is heavier than Block X.
B. Block Y is less dense than Block X.
C. Block Y has a smaller volume than Block X.
D. Block Y would float if more water were added.

- 17 The equation below represents the reaction of hydrogen iodide with water.

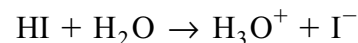

Which reactant in this equation acts as a Brønsted base?

A. HI
B. H_2O
C. H_3O^+
D. I^-

- 18 The diagram below represents particles of different elements in a crystal.

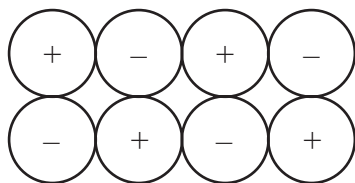

What type of bond holds these particles together?

- A. covalent
- B. hydrogen
- C. ionic
- D. polar

- 19 The graph below compares three states of a substance.

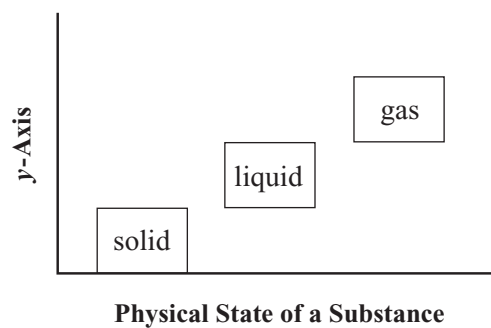

Which of the following choices is the **best** label for the *y*-axis?

- A. molecular density
- B. molecular motion
- C. neutron density
- D. neutron motion

- 20 In a 100 g sample of MgO, the ratio of the mass of magnesium to the mass of oxygen is 3:2. In a 50 g sample of MgO, what will the mass ratio be?
- A. 1:1
 - B. 2:3
 - C. 3:2
 - D. 3:4
- 21 Concrete is composed of Portland cement, rocks, sand, and water. Which of the following **best** describes concrete?
- A. an element
 - B. a compound
 - C. a homogenous mixture
 - D. a heterogeneous mixture
- 22 Four different gases are all observed to have the same temperature. Which of the following conclusions is supported by this observation?
- A. All four gases must have the same mass.
 - B. All four gases must have the same pressure.
 - C. All four gases must have equal numbers of particles.
 - D. All four gases must have equal average kinetic energies.
- 23 Atoms of element A and atoms of element B react to form a compound. In the reaction, the radius of each atom of element A is decreased.
- Which of the following explains this decrease in atomic radius in the reaction?
- A. The atoms of element A lose electrons to atoms of element B.
 - B. The atoms of element A gain neutrons from atoms of element B.
 - C. Nuclear particles are converted into energy in atoms of element A.
 - D. Protons become more densely packed in the nuclei of element A atoms.
- 24 Which of the following correctly describes a trend from top to bottom in the group 2 (2A) elements on the periodic table?
- A. Ionic radius decreases.
 - B. Ionic charge increases.
 - C. Atomic radius increases.
 - D. Atomic number decreases.

Questions 25 and 26 are open-response questions.

- **BE SURE TO ANSWER AND LABEL ALL PARTS OF EACH QUESTION.**
- **Show all your work (diagrams, tables, or computations) in your Student Answer Booklet.**
- **If you do the work in your head, explain in writing how you did the work.**

Write your answer to question 25 in the space provided in your Student Answer Booklet.

- 25 Sodium has an atomic number of 11 and a mass number of 23.
- Identify the types of subatomic particles located in the nucleus of a sodium atom. Compare the properties of each type of particle.
 - Where is **most** of a sodium atom's mass located? Explain your answer.
 - Identify the subatomic particles that are found in the energy levels outside the nucleus of a sodium atom. Describe the number and arrangement of these particles.
 - Explain the role of electrons in a chemical reaction between atoms of two different elements.

Write your answer to question 26 in the space provided in your Student Answer Booklet.

- 26 Silver (Ag) is a commonly used metal that easily tarnishes. The silver reacts with hydrogen sulfide (H_2S) in the air. This reaction produces silver sulfide (Ag_2S), a dull brownish compound, and hydrogen gas (H_2).
- Write a balanced equation for this reaction and identify the reaction type.
 - Explain why silver tarnishes faster in a heated room than in an unheated room.
 - Describe how you could slow down this reaction or prevent it from occurring.

Chemistry

SESSION 2

DIRECTIONS

This session contains seventeen multiple-choice questions and two open-response questions. Mark your answers to these questions in the spaces provided in your Student Answer Booklet. You may work out solutions to multiple-choice questions in the test booklet.

- 27 Which of the following occurs when a rigid container of gas is heated?
- A. The pressure inside the container increases.
 - B. The pressure inside the container decreases.
 - C. The pressure inside the container stays the same.
 - D. The pressure inside the container changes the composition of the gas.
- 28 Which of the following is the same for both hydrogen and potassium?
- A. atomic mass
 - B. total mass of neutrons
 - C. number of valence electrons
 - D. number of filled energy levels
- 29 Which of the following helps explain why honey dissolves more rapidly in hot water than in cold water?
- A. The honey and hot water form more covalent bonds.
 - B. The hot water is more chemically reactive with the honey.
 - C. The honey breaks down into free atoms more quickly in the hot water.
 - D. The greater motion of hot water molecules disperses the honey more quickly.
- 30 The addition of 500 J of energy to a block of iron causes a rise in the average kinetic energy of the atoms in the block. Which of the following instruments can **best** be used to observe this change?
- A. a ruler
 - B. a balance
 - C. a thermometer
 - D. a graduated cylinder

- 31 The bar graph below represents four elements and their relative atomic numbers.

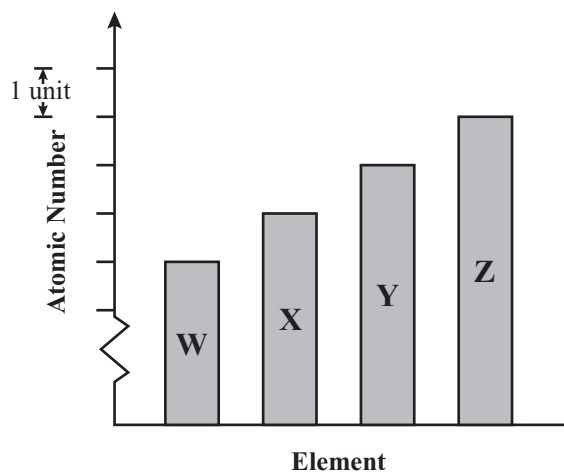

What would be the **most likely** positioning of these unknown elements in the periodic table?

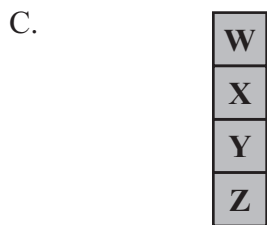
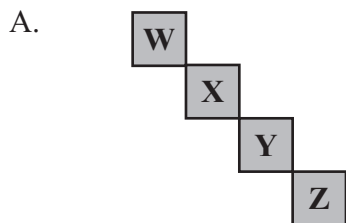

Question 32 is an open-response question.

- **BE SURE TO ANSWER AND LABEL ALL PARTS OF THE QUESTION.**
- **Show all your work (diagrams, tables, or computations) in your Student Answer Booklet.**
- **If you do the work in your head, explain in writing how you did the work.**

Write your answer to question 32 in the space provided in your Student Answer Booklet.

- 32 Sodium benzoate is a food preservative compound that has both ionic and covalent bonds. The structural formula for sodium benzoate is represented in the diagram below. The atoms within the formula are numbered.

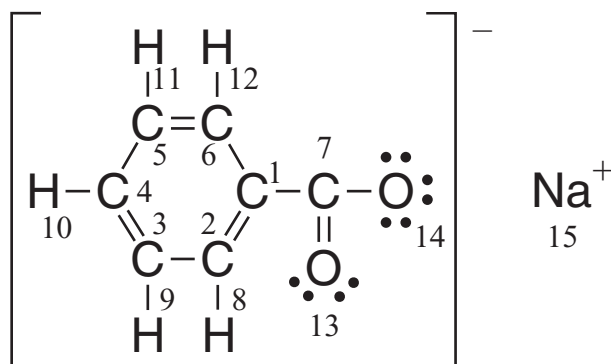

- Explain what makes a bond covalent.
- In the structure above, identify **two** atoms by number that are connected by a covalent bond. Explain your reasoning.
- Explain why sodium benzoate is considered to be an ionic compound.

Mark your answers to multiple-choice questions 33 through 38 in the spaces provided in your Student Answer Booklet. Do not write your answers in this test booklet, but you may work out solutions to multiple-choice questions in the test booklet.

- 33 The illustration below shows the lab equipment set up by a student to find the melting and freezing points for naphthalene, a chemical used as an insect repellent.

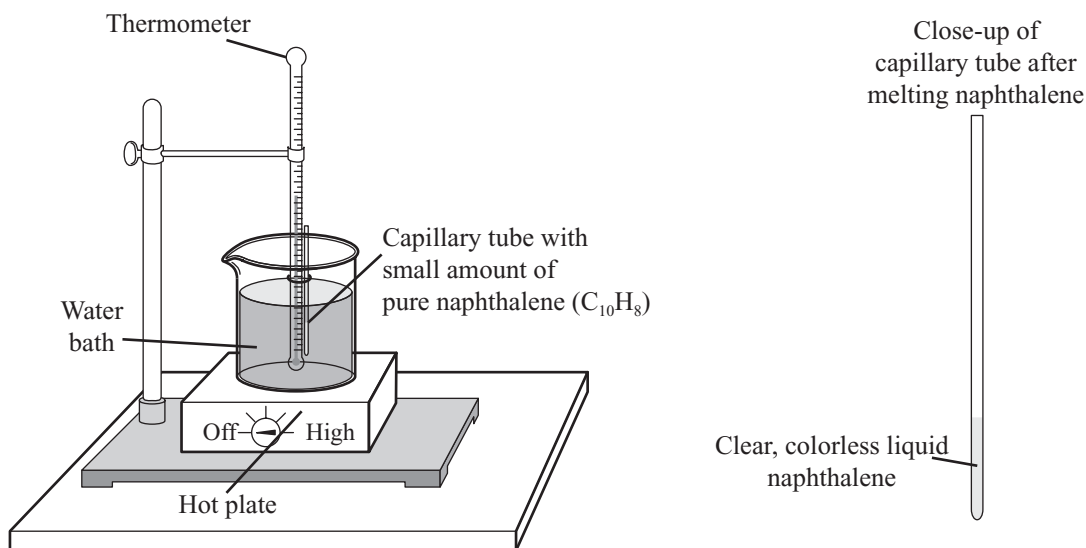

A small sample of solid naphthalene ($C_{10}H_8$) is placed in the capillary tube attached to the thermometer and is heated in the water bath until the white solid melts. The student then turns the heat off and observes the sample as it cools, recording the temperature at regular intervals.

What will **most likely** happen to the colorless liquid naphthalene when the temperature reaches the freezing point of naphthalene?

- A. The naphthalene will change into a yellow liquid.
- B. The naphthalene will crystallize into a white solid.
- C. The naphthalene will begin to form small bubbles.
- D. The naphthalene will disappear from the capillary tube.

- 34 Which of the following substances has the highest concentration of hydrogen ions in solution?
- A. bleach – pH 13
 - B. water – pH 7
 - C. tomato juice – pH 4
 - D. vinegar – pH 3
- 35 Which of the following is an example of nuclear fusion?
- A. Hydrogen-1 and hydrogen-2 combine to form helium-3.
 - B. Polonium-210 decays into lead-206 and an alpha particle.
 - C. Carbon-14 breaks down into a beta particle and nitrogen-14.
 - D. Uranium-235 and a neutron produce barium-141, krypton-92, and three neutrons.
- 36 What is the **correct** name for the compound with the chemical formula NH_4NO_3 ?
- A. ammonium nitrate
 - B. hydro-nitrogen oxide
 - C. ammonia mononitrite
 - D. nitro-hydrogen nitrate

- 37 The table below contains data from one trial in an experiment designed to determine the molar mass of a sample of an unidentified compound X in the gaseous state.

	Trial 1
Mass of gas (g)	6.42
Gas volume (L)	4.48
Density (g/L)	1.43
Temperature (°C)	0.0
Pressure (atm)	1.00

Based on the data gathered in this first trial, what is the molar mass of the compound?

- A. 19.4 g/mol
 - B. 28.8 g/mol
 - C. 32.1 g/mol
 - D. 144 g/mol
- 38 Which of the following has the **greatest** mass?
- A. 1 mole of H_2
 - B. 2 moles of K
 - C. 3 moles of Mg
 - D. 4 moles of He

Question 39 is an open-response question.

- **BE SURE TO ANSWER AND LABEL ALL PARTS OF THE QUESTION.**
- **Show all your work (diagrams, tables, or computations) in your Student Answer Booklet.**
- **If you do the work in your head, explain in writing how you did the work.**

Write your answer to question 39 in the space provided in your Student Answer Booklet.

- 39 To make vanilla extract, a food chemist adds two dried vanilla beans to 250 mL of pure ethanol (C_2H_5OH). Although vanillin, the primary flavoring compound present in the beans, is soluble in ethanol, the rate at which it dissolves is slow.
- a. Describe **two** methods the food chemist could use to increase the rate at which the vanillin in the beans dissolves in the ethanol.
 - b. Explain how each of these methods would work, at the molecular level, to increase the dissolving rate.

Mark your answers to multiple-choice questions 40 through 45 in the spaces provided in your Student Answer Booklet. Do not write your answers in this test booklet, but you may work out solutions to multiple-choice questions in the test booklet.

- 40 An iron nail weighing 5.10 g is allowed to react with oxygen, according to the reaction below.

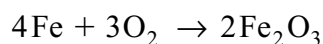

A layer of iron(III) oxide forms on the nail, increasing the nail's mass. How much oxygen has reacted with the iron if the mass of the nail has increased to 5.89 g?

- A. 0.79 g O₂
- B. 2.00 g O₂
- C. 7.00 g O₂
- D. 10.99 g O₂

- 41 The two samples of gas represented below have the same volume, temperature, and pressure.

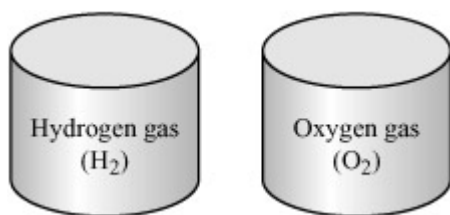

Based on this information, these two samples of gas must also have the same

- A. chemical reactivity.
- B. density.
- C. mass.
- D. number of molecules.

- 42 Based on its position on the periodic table, which of the following elements is a nonmetal?

- A. potassium (K)
- B. vanadium (V)
- C. nickel (Ni)
- D. bromine (Br)

- 43 Three 10 g samples of sugar are represented below.

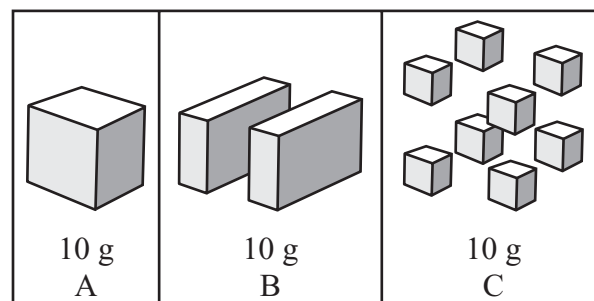

Sample A dissolves in water more slowly than sample B. Sample B dissolves more slowly than sample C. Which of the following best explains why sample A dissolves most slowly?

- A. It has the most volume.
- B. It has the smallest surface area.
- C. It has the largest number of sugar molecules.
- D. It has the fewest bonds between sugar molecules.

- 44 The illustration below shows a label from a dietary supplement.

Calcium Citrate Dietary Supplement		
Supplement Facts Serving Size: 2 tablets		
	Amount per Serving	% Daily Value
Calcium (as high-density calcium citrate)	400 mg	40
Ingredients: Calcium citrate, polyethylene glycol, croscarmellose sodium, hydroxypropylmethyl cellulose, color added, magnesium silicate, magnesium stearate		

Why is this dietary supplement **best** characterized as a mixture instead of a pure substance?

- A. The percent daily value is less than 100 percent.
- B. Calcium citrate contains more than one element.
- C. A tablet contains different chemical compounds.
- D. Calcium citrate is composed of nonmetallic elements.

- 45 Oxygen (O) atoms have six valence electrons and beryllium (Be) atoms have two valence electrons. Which of the following is the **correct** formula for a compound made of oxygen and beryllium?

- A. BeO
- B. BeO₂
- C. Be₂O
- D. Be₂O₆

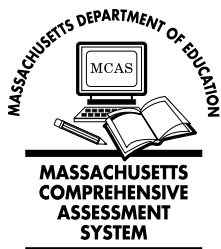

Massachusetts Comprehensive Assessment System

Chemistry Formula and Constants Sheet

Common Polyatomic Ions

Ion	Ionic Formula
Ammonium	NH_4^+
Carbonate	CO_3^{2-}
Hydroxide	OH^-
Nitrate	NO_3^-
Phosphate	PO_4^{3-}
Sulfate	SO_4^{2-}

Ideal Gas Law: $PV = nRT$

Absolute Temperature Conversion: $K = ^\circ\text{C} + 273$

Definition of pH: $\text{pH} = -\log[\text{H}_3\text{O}^+]$

Specific Heat of Water: $c_{\text{H}_2\text{O}} = 1.00 \text{ cal/g} \cdot ^\circ\text{C} = 4.18 \text{ J/g} \cdot ^\circ\text{C}$

Mole-Volume of Ideal Gas at STP: 22.4 L at STP

Ideal Gas Constant: $R = 0.0821 \text{ L} \cdot \text{atm/mol} \cdot \text{K} = 8.314 \text{ L} \cdot \text{kPa/mol} \cdot \text{K}$

Avogadro's number: 6.02×10^{23}

STP: 1 atm, 0°C

Nuclear Particles

Name	Symbol
Alpha particle	α or ${}^4_2\text{He}$
Beta particle	β or ${}^0_{-1}e$
Gamma ray	γ
Neutron	1_0n

Massachusetts Comprehensive Assessment System

Periodic Table of the Elements

Period	Group (Family)																		
	1A	2A	8B										3A	4A	5A	6A	7A	8A	
1	1.00794 H 1 Hydrogen																	4.00260 He 2 Helium	
2	6.941 Li 3	9.01218 Be 4																18.998403 F 9	20.179 Ne 10
3	22.98977 Li 3	24.305 Mg 12																35.453 Cl 17	39.948 Ar 18
4	39.0983 K 19	40.08 Ca 20	44.9559 Sc 21	47.88 Ti 22	50.9415 V 23	51.996 Cr 24	54.9380 Mn 25	55.847 Fe 26	58.69 Ni 28	58.9332 Co 27	63.546 Cu 29	65.39 Zn 30	69.72 Ga 31	72.59 Ge 32	74.9216 As 33	78.96 Se 34	79.904 Br 35	83.80 Kr 36	
5	85.4678 Rb 37	87.62 Sr 38	88.9059 Y 39	91.224 Zr 40	92.9064 Nb 41	95.94 Mo 42	98 (98) Tc 43	101.07 Ru 44	106.42 Pd 46	102.906 Rh 45	107.868 Ag 47	112.41 Cd 48	114.82 In 49	118.71 Sn 50	121.75 Sb 51	127.60 Te 52	126.905 I 53	131.29 Xe 54	
6	132.905 Cs 55	137.33 Ba 56	138.906 La 57	178.49 Hf 72	180.948 Ta 73	183.85 W 74	186.207 Re 75	190.2 Os 76	195.08 Pt 78	192.22 Ir 77	196.967 Au 79	200.59 Hg 80	204.383 Tl 81	207.2 Pb 82	208.980 Bi 83	209 (209) Po 84	210 (210) At 85	222 (222) Rn 86	
7	223 (223) Fr 87	226.025 Ra 88	227.028 Ac 89	261 (261) Rf* 104	262 (262) Db 105	263 (263) Sg 106	262 (262) Bh 107	265 (265) Hs 108	269? (269?) Mt 109	268? (268?) Ds 110	268? (268?) Nh 111	268? (268?) Fl 112	268? (268?) Mc 113	268? (268?) Lv 114	268? (268?) Ts 115	268? (268?) Og 116	268? (268?) Lr 103	268? (268?) Uue 104	

Mass numbers in parentheses are those of the most stable or most common isotope.

Lanthanide Series

Actinide Series

**Grades 9/10 Chemistry
Spring 2006 Released Items:
Standards and Correct Answers**

Item No.	Page No.	Standard	Correct Answer (MC)*
1	448	3.1	D
2	448	1.4	A
3	448	9.3	B
4	448	5.2	A
5	449	2.3	B
6	449	4.7	B
7	449	8.1	C
8	449	1.3	B
9	450	2.3	D
10	450	9.3	D
11	451	6.1	
12	452	7.1	A
13	452	4.6	B
14	453	2.10	A
15	453	1.1	A
16	453	1.1	C
17	453	8.1	B
18	454	4.1	C
19	454	1.3	B
20	455	2.2	C
21	455	1.2	D
22	455	6.2	D
23	455	4.1	A
24	455	3.4	C
25	456	2.3	
26	457	5.2	
27	458	6.1	A
28	458	3.3	C
29	458	7.2	D
30	458	6.2	C
31	459	3.1	D
32	460	4.1	
33	461	1.1	B
34	462	8.1	D
35	462	2.9	A
36	462	4.7	A
37	462	5.3	C
38	462	5.3	B
39	463	7.2	
40	464	2.2	A
41	464	6.1	D
42	464	3.2	D

Item No.	Page No.	Standard	Correct Answer (MC)*
43	464	7.2	B
44	465	1.2	C
45	465	4.6	A

* Answers are provided here for multiple-choice items only. Sample responses and scoring guidelines for open-response items, which are indicated by shaded cells, will be posted to the Department's Web site later this year.